

SoundLok® Sound-Isolation Rooms – Upgradeable to VAE® Technology

A SoundLok Sound-Isolated Practice Room with built-in components to allow upgrading to Virtual Acoustic Environments (VAE) at any time in the future. Upgrade is possible on practice rooms with areas up to 328 ft² (30.5 m²)

- Multiple size options accommodate one musician or ensembles up to fifteen musicians
- Sizes range from 5'8" x 4'5" to 19'5" x 25'8" (1727 x 1346 mm to 5918 x 7823 mm)
- Internal ceiling height ranges from 7'6" (2286 mm) to 10' (3048 mm) in 6" (152 mm) increments
- Can relocate, reconfigure, and upgrade with VAE
- UL GREENGUARD certified - product certified for low chemical emissions: ul.com/gg - UL 2818
- Five-year warranty

Sound-Isolation and Internal Acoustics

- Ideal acoustical environment for uninterrupted music instruction, rehearsal, recording, etc
- Acoustically dry environment accurately reflects sound
- Rated: NIC 63 room to room; NIC 41 hallway to room
- Ambient noise at center of module: NC 25 with lighting and ventilation systems on
- Acoustically seals to floor without attachments, adhesives or caulking

Practice Room Construction

- Wall and ceiling panels flame spread <25 and smoke developed <450
- ETL classified room wiring system
- Wall and ceiling panels feature powder-coat paint available in oyster, warm sand or vanilla finish
- Floor railings and doors are available in charcoal grey or warm beige finish
- Wall frames are 14-gauge steel channels and ceiling frames are 16-gauge steel channels
- Frame compensates for up to 3/4" (19 mm) variation in floor surface
- Includes 1-1/4" (32 mm) neoprene pad to isolate floor vibration
- Interior surfaces are 22-gauge perforated or solid steel; exterior surface is 16-gauge solid steel
- Panel perimeters feature continuous acoustical gaskets and alignment locks
- Doors are pre-hung on 36" (914 mm) frame for either right or left-hand swing, can open either in or out
- Doors feature a double acoustical seal with a cam type hinge and an acoustically-engineered window
- Corner sections with built-in speaker enclosures and wiring
- Wall panels with built-in microphone mounts and wiring
- Control panel with built-in wiring for VAE

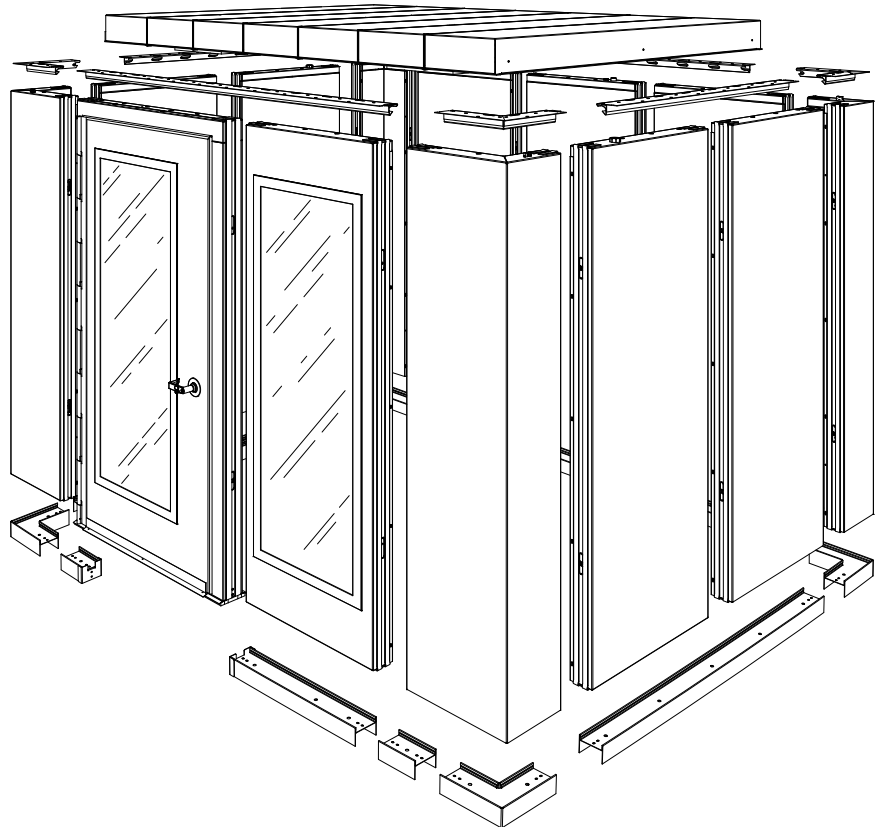

Installation Requirements

- For internal room heights of 7'6" (2286 mm), overall ceiling height of 9' (2743 mm) is required for units with internal ventilation fan, 10'7" (3226 mm) for direct connect HVAC rooms
- For maximum performance, spacing of 12" (305 mm) between rooms is recommended
- 120V, 60Hz, 20A, dedicated circuit
- Installation by Wenger service technicians is standard

Mechanical Systems

- Built-in components and wiring to allow for easy upgrade to VAE without module disassembly
- Built-in LED lighting to minimize power consumption; Provides 80 fc at 36" (914 mm) above the floor for a 7' 6" (2286 mm) high room
- Room has an ETL Classified wiring system;
 - power panel includes one quad receptacle, Light and/or Air switches and 20' (6096 mm) power cable
 - larger rooms have a communications panel that includes one quad receptacle and four double junction boxes for customer- installed fire alarms, clocks, phone lines, etc
 - requires wiring a manufacturer supplied connector by a local electrician
- Internal room fan system typically exchanges ambient surrounding air every 1-1/2 to 2 minutes depending on room size
- Plenum and ducts feature acoustically isolating construction
- Contact Wenger for cfm requirements based on room size for direct connect HVAC

Options

- Window wall panels are 24" (610 mm) windows
- Communications panel includes one quad receptacle and four double junction boxes for customer-installed fire alarms, clocks, phone lines, etc
- Sound-isolating floating floor system (recommended for installations above grade)
- Closure panels for use between modules
- Adaptable for direct connection to building HVAC system
- 48" (1219 mm) door and 6' (1828 mm) wide double door with removable mullion
- Custom options include: one-way glass, double doors, and more
- 57-1/4"w x 21-1/4"h (1454 x 540 mm) glass mirror
- Mountable Korg tuner/metronome

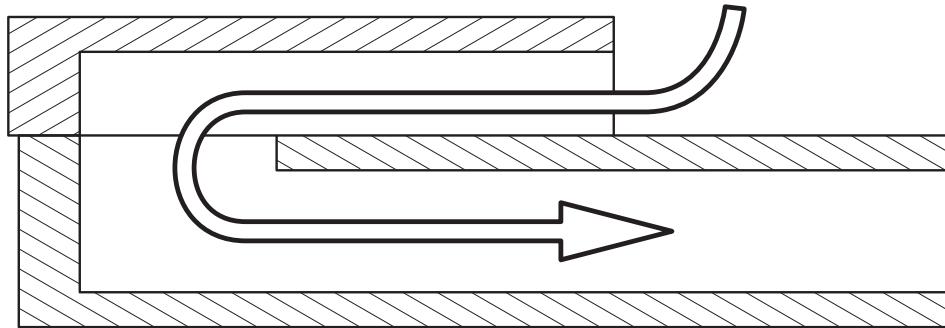

Acoustically quieted airflow system can act alone or be attached to building HVAC systems.

Wenger

JRCLANCY

GEARBOSS

© 2024 Wenger Corporation
USA/2024-03

Minnesota Location

Wenger Phone 800.4WENGER (493-6437) Wenger Worldwide +1.507.455.4100 | Parts & Service 800.887.7145 | wengercorp.com
GearBoss Phone 800.493.6437 | gearboss.com
555 Park Drive, PO Box 448 | Owatonna | MN 55060

New York Location

J.R. Clancy Phone 800.836.1885 JR Clancy Worldwide +1.315.451.3440 | jrclancy.com | 7041 Interstate Island Road | Syracuse | NY 13209